

Effects of matrix characteristics on diamond composites

Y. S. LIAO, S. Y. LUO

Department of Mechanical Engineering, National Taiwan University, Taipei, Taiwan

A series of cobalt-matrix diamond composites was fabricated by hot pressing, and their microstructure, physical properties, transverse rupture strength and resulting fracture surface were studied in detail. Segments of the diamond composites were manufactured, and a one-segment circular sawblade was used for the evaluation of the sawing performance. Results show that the fracture surface of composites containing a cobalt matrix exhibits an excellent ductile appearance, while the fracture surface of composites containing an additive of tin powder in the cobalt matrix displays a less ductile behaviour due to the existence of a tin-rich brittle phase. It is also found that a diamond composite having low porosity, high hardness, and less surface attack of diamond particles will result in a low value of radial sawblade wear.

1. Introduction

Metal-bonded diamond composites have been widely used as drilling bits, sawblades and grinding wheels. Various techniques to fabricate these composites are available [1, 2]. They include cold pressing and sintering, hot pressing and infiltration. Selection of one of these manufacturing methods is based primarily on attaining the required physical properties of the metal bond without affecting the physical integrity of the diamond contained.

A number of metals such as cobalt, tungsten, nickel and iron, whose chemical affinity for carbon is high, are often used for bonding diamonds in tools. When diamond is heated in the presence of these metals, diamond integrity will be affected through surface attack during the manufacturing process. However, copper, tin and bronze metal powders, which have a poor chemical affinity for carbon, are also at times extensively used, since diamond is not affected significantly by these metals in the manufacturing process of composites. Depending on the specific applications required, the matrix behaviour can be varied by the addition of various alloying elements or alternatively by modifying the production conditions.

The wear-resistant diamond grains are held in a metallic bond. From the point of view of improving the tool's cutting ability, a relatively brittle bond, e.g. the commonly used 80% Cu–20% Sn, will sometimes allow the diamonds to do the cutting, while a tougher bond, e.g. 90% Cu–10% Sn, has a tendency to glaze [2]. Generally speaking, the metal bond must be designed to wear at the same rate as the diamond grits so that when the diamond particles become worn, new grits will expose to facilitate constant efficient cutting [3].

In previous studies, Bronshtein *et al.* [4] studied the reaction of diamond with hard metals such as cobalt, tungsten and tungsten carbide. They stated that a successful composite tool design affords protection to

diamond during the manufacture of a composite, and ensures the formation of a ductile cobalt bond around the diamond grains, which prolongs the useful life of tools operating under conditions of intense abrasive wear and heavy dynamic loads. However, few studies relating the nature of metal bonds to the properties of diamond composites have been reported.

In this paper, composites containing several cobalt-base bonds were fabricated into net shape using a hot-pressing method, and their microstructures and properties were studied. In addition, a circular sawblade with only one segment of diamond composites brazed to the rim of a steel core was manufactured. Sawing operations were carried out for evaluation of the sawing performance.

2. Experimental procedure

Five different bonds of diamond composites were fabricated for experimental studies. Table I gives the compositions of the original powders for the composites fabricated. Powders of each composite were blended for 1 h in a rotary mixer (∞ -shape). The mixed powders were hot-pressed in graphite moulds at 820 to 840 °C for 15 min under nitrogen gas and a mild pressure. Hot-pressed composites were cooled down to room temperature and then the pressure was

TABLE I Compositions of the diamond composites

Specimen	Bond		Diamond (vol %)	Diamond size (μm)
	Composition (wt %)	Vol %		
A	100Co	95	5	300–425
B	95Co–5Sn	95	5	300–425
C	95Co–5Ni	95	5	300–425
D	95Co–5Ag	95	5	300–425
E	95Co–5W	95	5	300–425

relieved. The rectangular size of diamond composites fabricated was 40 cm × 7 cm × 10 cm.

Samples for microstructure studies were prepared by sectioning the composites by an electric discharge machine. These samples were abraded by a rotary diamond disc and then mirror-polished with diamond paste. The microstructure of the specimen was examined by an optical microscope or a scanning electron microscope (SEM).

The bulk density of the composites was measured by Archimedes' method, and the porosity of specimens was also estimated. The bond hardness of diamond composites was measured with a Rockwell B hardness tester using a standard B indenter. The measurements were taken at six points on the sides of the specimen ground by No. 1000 emery paper.

Transverse rupture strength (TRS) of the composites was measured by a three-point bending test. The resulting fracture surfaces from bending tests were examined by SEM for evaluation of the bond structure and diamond distribution. In addition, the extent of the diamond's thermal damage was analysed.

Segments of the diamond composites were manufactured, and a circular sawblade with only one segment was used in the test. The workpiece material was

Indian red granite. After sawing, the worn segment surface of the diamond composite was examined by SEM, and the radial sawblade wear was measured by a toolmaker's microscope.

3. Results

The diamond composites produced were cut into a few sections, their structures were examined by SEM techniques and their physical, mechanical and sawing properties were determined.

3.1. Microstructure of the composites

Fig. 1a and b show typical SEM observations of the matrix of specimens B and D, respectively. Specimen B, which contains tin powder in the cobalt matrix, shows fewer pores. Clustering of tin-rich particles (white regions) is also observed. A larger amount of isolated pores was observed in specimen D with a silver-cobalt bond of the composite. Rounded pores indicate adequate sintering. Moreover, it can be seen that in both types of specimen, the boundaries between metal powders are not clearly outlined. Typical SEM photomicrographs of the diamond-matrix interface of specimens B and D are given in Fig. 2a and b,

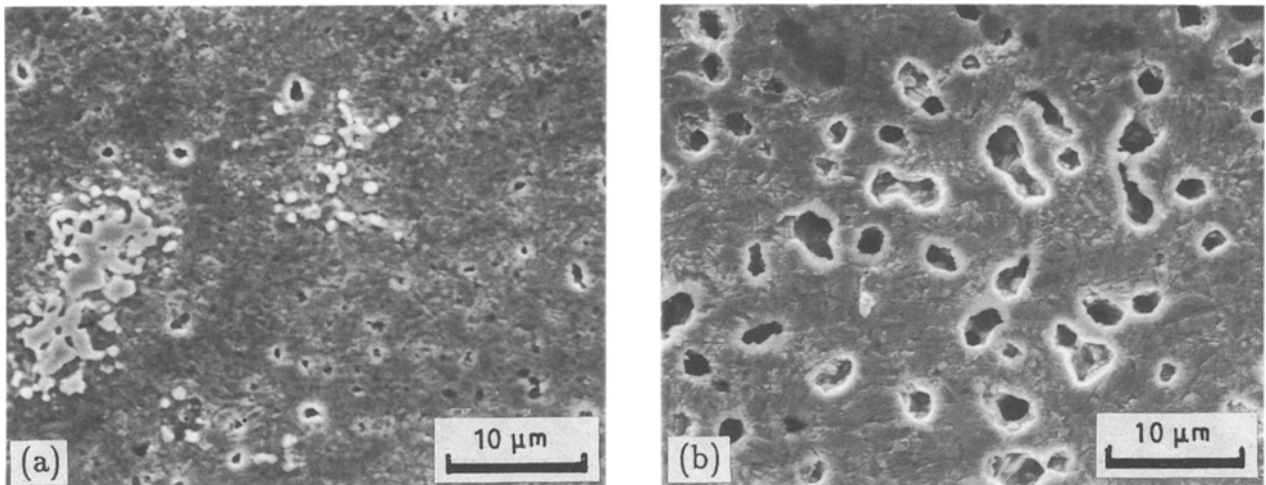

Figure 1 SEM photomicrographs of matrix for diamond composites of (a) specimen B, (b) specimen D.

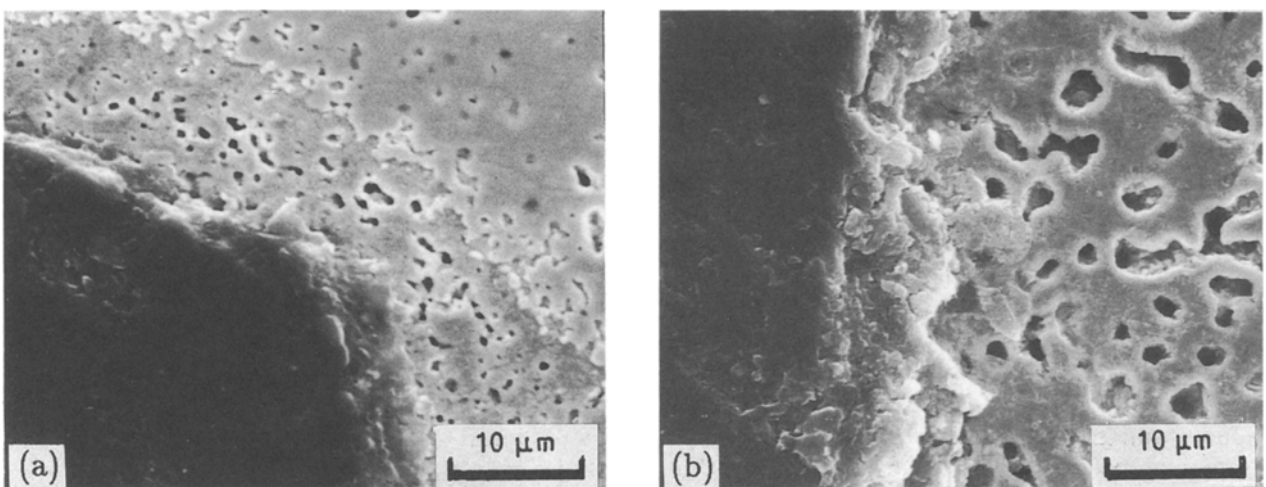

Figure 2 SEM photomicrographs of diamond-matrix interface for (a) specimen B, (b) specimen D.

respectively. The black regions represents diamond grains. Many pores around the diamond can also be seen.

3.2. Bulk density

Table II shows the measured bulk density and the estimated true porosity for five types of diamond composite. From the table, the effect of additive metals (Sn, Ni, Ag, W) in the cobalt matrix on the degree of densification can be seen. The tin-cobalt bond of specimen B exhibits a lower porosity than the cobalt bond of specimen A. This is primarily due to the presence of a liquid phase, which, in general, increases the degree of densification in the sintering process [5].

There seems to have been no significant improvement in the degree of densification when silver powder is added to the cobalt matrix during hot pressing. The diamond composite containing an additive of tungsten in the cobalt matrix shows the highest porosity among all specimens. Such a distinct increase in porosity is believed to be due to the high strength and rigidity of tungsten, which causes poor packing characteristics. The composites obtained by adding nickel powder to the cobalt matrix display a lower degree of densification than those with a cobalt bond. This implies that the addition of nickel particles to the cobalt matrix has not aided densification. Hence, in order to control the desirable densification of the diamond composites, the sintering behaviour and processing of composites in hot pressing need to be carefully treated.

3.3. Bond hardness

The measured bond hardness is shown in Fig. 3. It can be seen that specimen B has the highest hardness value with least variability among all specimens. Possible causes of the increase of hardness of the tin-cobalt bond could be solution hardening in Co-Sn and lower porosity. For the composites with silver particles added to the cobalt matrix, there is a lower hardness value than that of a pure cobalt bond.

The diamond composite with nickel-cobalt bonding has the lowest hardness value with more variability among all specimens. This is due to the high porosity in the nickel-cobalt bond. Specimen E, which contains tungsten powder in the cobalt matrix, shows a similar bond hardness to that of specimen A, but has a larger variability.

From the results discussed above, it is concluded that the variation in hardness is mainly attributable to

TABLE II Measured bulk density and estimated true porosity of five different diamond composites

Specimen	Average bulk density (g cm^{-3})	Density range (g cm^{-3})	Average true porosity (%)
A	8.08	7.93-8.16	6.1
B	8.17	8.14-8.21	3.8
C	7.92	7.81-8.02	7.9
D	8.08	7.99-8.17	6.3
E	7.44	7.03-7.94	18.1

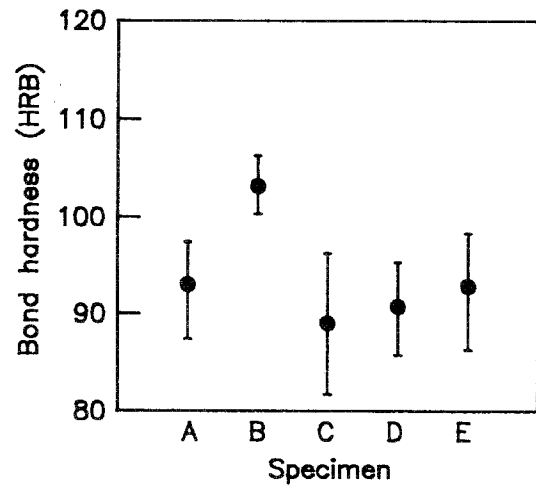

Figure 3 Bond hardness of diamond composites.

the properties of the additive elements in the cobalt matrix, and to solution hardening and porosity. In general, a lower hardness variability indicates better uniformity in bond processing.

3.4. Transverse rupture strength and observations of fracture surfaces

TRS values for the five types of diamond composite are given in Fig. 4, and the resulting fracture surfaces are shown in Figs 5 and 6. The diamond composite with a cobalt matrix (specimen A) results in the highest TRS value among all composites, and the microstructure of fracture surfaces observed by SEM reveals ductile cup and cone behaviour (Fig. 5a). This implies that there is a very good bond among cobalt powder particles. The major effect of the cobalt powder and the manufacturing process on the diamond particles is to produce etching pits of a surface texture which aids in the bonding of crystals in the matrix bond (Fig. 6a), and prevents excessive pull-out. In addition, the colour on the diamond surface is changed from the original yellow-green to grey-black with a little green.

Specimen B, which contains the additive of tin particles in the cobalt matrix of the diamond composite, shows a rather lower value with more variability of TRS than that of specimen A. This is

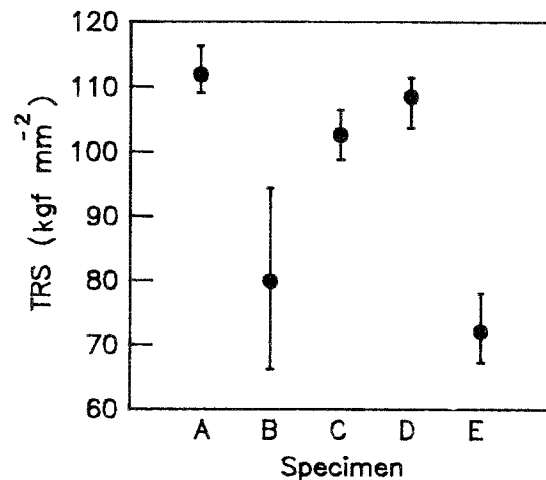

Figure 4 Transverse rupture strength for five different diamond composites.

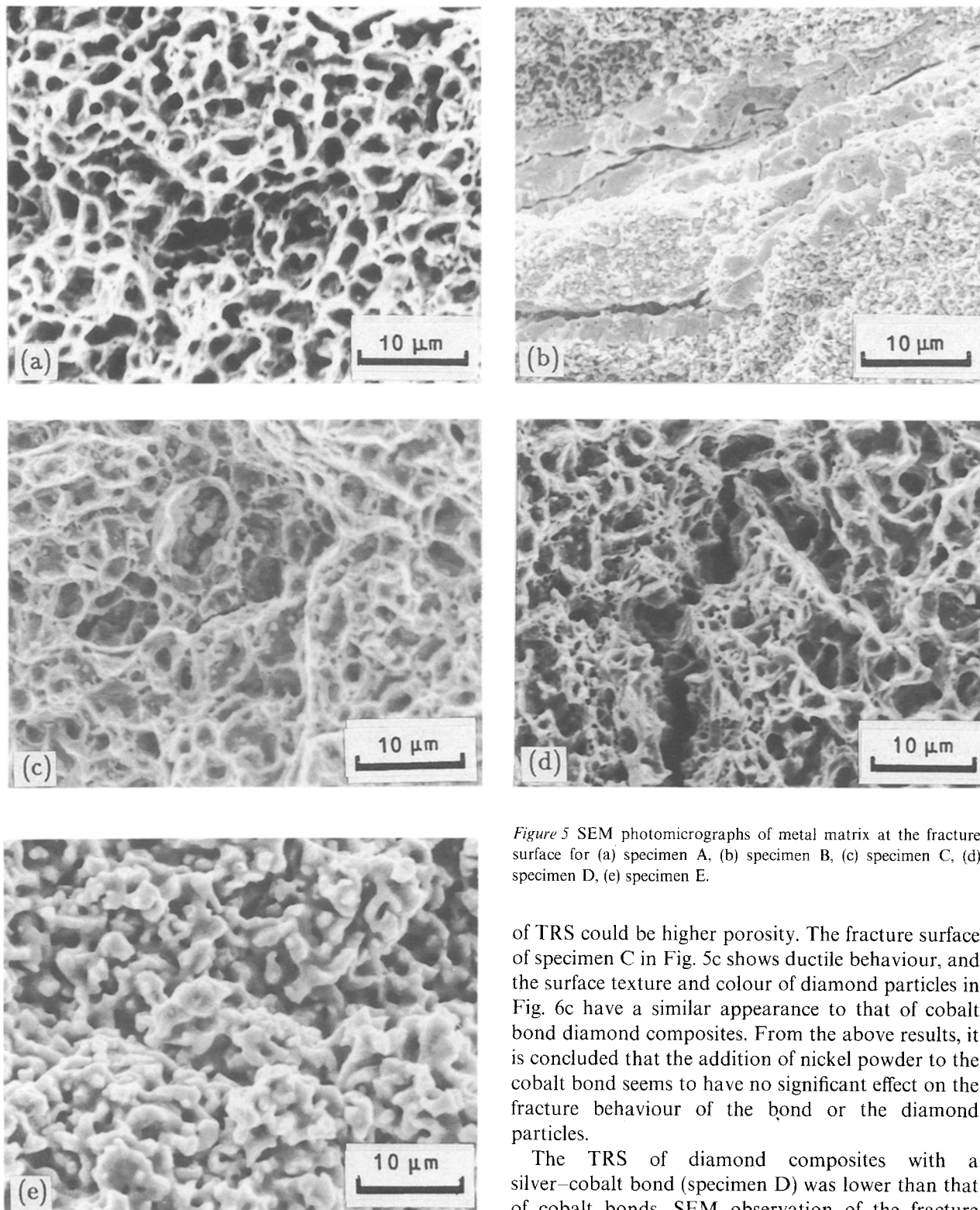

Figure 5 SEM photomicrographs of metal matrix at the fracture surface for (a) specimen A, (b) specimen B, (c) specimen C, (d) specimen D, (e) specimen E.

of TRS could be higher porosity. The fracture surface of specimen C in Fig. 5c shows ductile behaviour, and the surface texture and colour of diamond particles in Fig. 6c have a similar appearance to that of cobalt bond diamond composites. From the above results, it is concluded that the addition of nickel powder to the cobalt bond seems to have no significant effect on the fracture behaviour of the bond or the diamond particles.

The TRS of diamond composites with a silver-cobalt bond (specimen D) was lower than that of cobalt bonds. SEM observation of the fracture surface obtained from specimen D (Fig. 5d) shows a ductile appearance, and it has a concave crack. The crack sites were examined by energy-dispersive analysis of X-rays (EDAX), and it was found that they were sites of silver clustering. The surface texture of diamond grains of the composites containing a silver powder additive in the cobalt bond (Fig. 6d) depicts more etching pits than that of the composites with a cobalt bond, and it is black and coal-like in appearance. This implies that the physical integrity of diamond particles of the cobalt-silver composites has been affected.

The lowest TRS value among all diamond composites is for composites with tungsten particles added

attributed to the occurrence of a tin-rich brittle phase (see Fig. 5b). The fracture surface of specimen B shows a less ductile appearance. However, the surface texture and colour of diamond particles (Fig. 6b) are not affected significantly. This is probably due to the tin-rich brittle phase which interacts a little with the diamond particles. This implies that the addition of tin powder to the cobalt matrix has a very positive effect on the physical integrity of diamond particles.

The diamond composites containing nickel and cobalt (specimen C) had a lower value of TRS than that of specimen A. A possible cause for the decrease

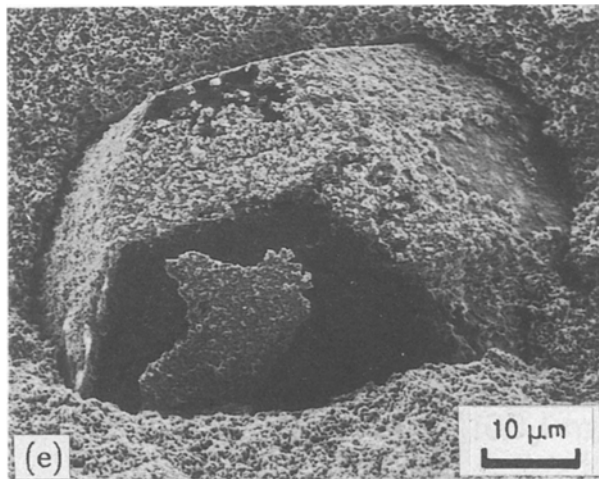
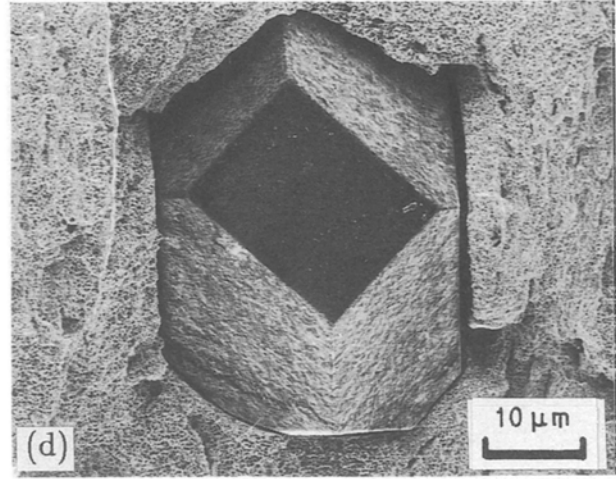
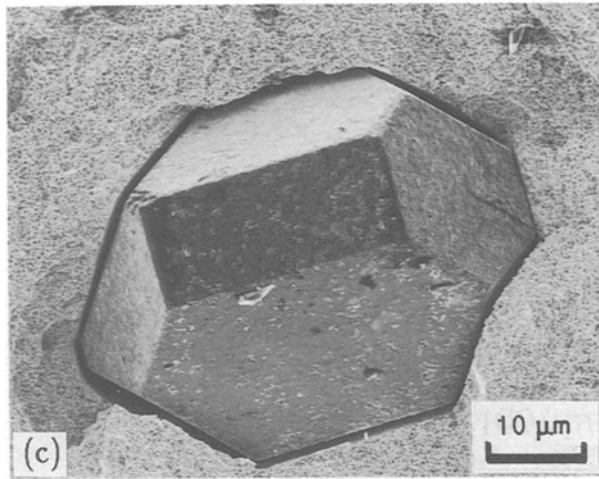
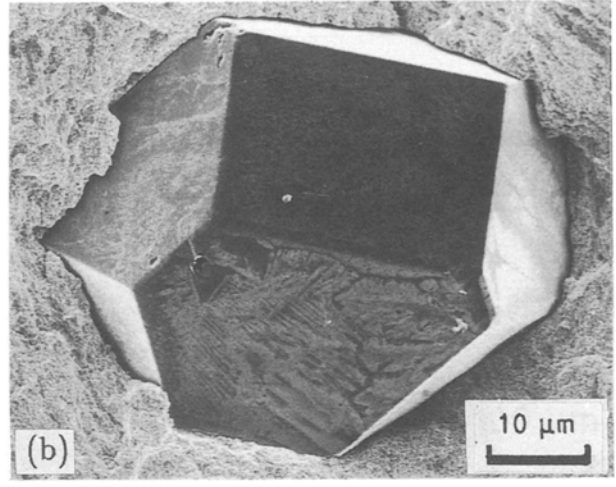
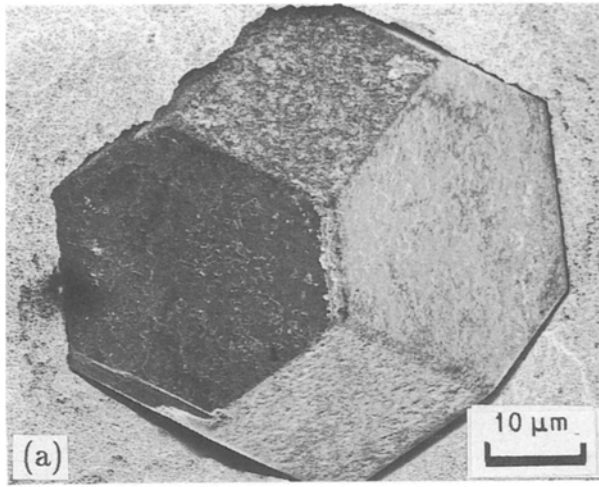

Figure 6 SEM observations of diamond particles on the fracture surface for (a) specimen A, (b) specimen B, (c) specimen C, (d) specimen D, (e) specimen E.

to the cobalt matrix. This is a result of the high porosity. The resulting fracture surface as shown in Fig. 5e exhibits a less ductile appearance. The photomicrograph shows the round surfaces of bond particles that have not sintered with any adjacent particles. This would lead to a decrease of bonding strength. Fig. 6e shows the diamond site of the fracture surface of specimen E. The surface layers of diamond crystals are covered by bond powders. This implies that the bonding strength between diamond grains and the tungsten-cobalt bond is very strong. In addition, the diamond grains had a grey-black appearance.

3.5. Sawing operation for evaluation of the diamond composites

Fig. 7 shows the circular sawblade with only one diamond segment used in the test. The sawing conditions are shown in Table III. SEM observations of the worn segment working surface after sawing of granite are shown in Fig. 8. The appearance of worn diamond can be broadly classified as whole particle, polished (flattened) particle, microfractured particle, macrofractured particle and pulled-out particle. The results obtained from sawing tests showed that specimen B

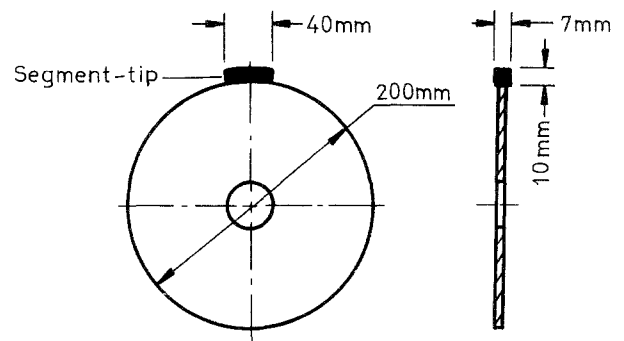

Figure 7 Sawblade geometry.

TABLE III Sawing conditions

Conditions	Value
Blade surface speed (m s^{-1})	30
Traverse rate (m min^{-1})	1
Depth of cut (mm)	0.2
Area sawn (cm^2)	630
Coolant	Water

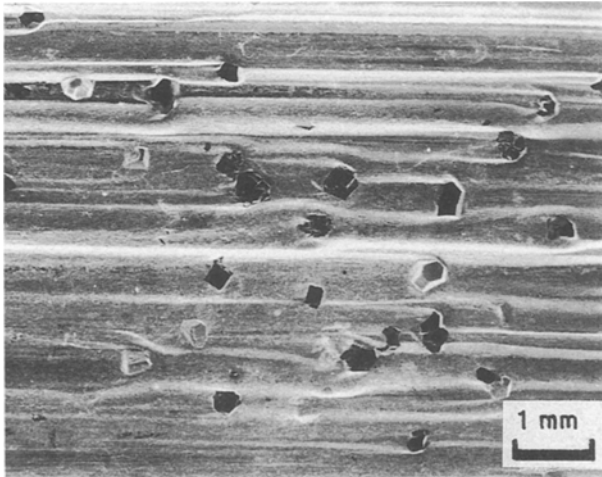

Figure 8 Worn surface of sawblade after sawing.

which contains a tin-cobalt diamond composite exhibits the highest proportion of microfracture grits among all composites. Microfracture grits are desirable because they help free cutting in the sawing process. On the other hand, the amounts of macrofractured grits and polished grits generated by specimens A, C, D and E are higher than those of specimen B. When there is a sufficiently large number of polished and macrofractured diamond particles existing at the sawblade's working segment surface, the sawblade often has a glazed appearance. The resistance to bond wear can be controlled by the hardness, porosity of matrix, and the degree of bonding among metal powders. The radial sawblade wear of the diamond composites is shown in Fig. 9. It is found that a decrease of the radial sawblade wear is probably the result of less surface attack of the diamond grains and lower porosity. In addition, the radial sawblade wear is decreased with an increase of bond hardness.

4. Discussion

As a result of the experimental work conducted during this investigation, understanding and additional knowledge regarding the graphitization of diamond composites is needed. Because the diamond composites were fabricated at high temperature, the graphitization of diamond might occur, and this could cause the diamond structure to break up. It is noted that the volume expansion which accompanies

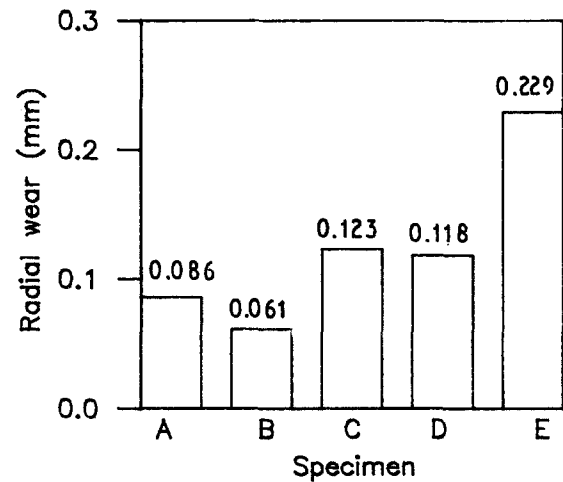

Figure 9 Radial sawblade wear for five different diamond composites.

graphitization would also produce stresses leading to the microcracking of diamond. Bex and Shafto [6] and Mehan and Hibbs [7] have shown that graphitization is the primary cause for thermal degradation of sintered diamond compacts. Naidich *et al.* [8] also showed that the main factors which cause a decrease of the strength of a diamond-metal bond are diffusion porosity and diamond surface graphitization. By eliminating the action of the above factors, it is possible to retain the high strength of a diamond-to-metal bond, and this can be obtained when metals having high chemical affinity to carbon are employed.

In this investigation, the diamonds of all specimens except specimen B have some black coating appearance. X-ray diffraction analysis shows that it is very insensitive to surface graphitization. Hence, this black appearance of the diamonds may not be true graphitization which involves the transition from diamond to graphite. Vornov *et al.* [9] have also shown that metallic constituents are necessary for diamond-to-graphite conversion in the temperature range of 850 to 1000°C. Hence, the physical integrity of the diamond in this work may not be affected significantly.

5. Conclusions

From the results of this work, the following conclusions can be drawn.

1. Adding tin powder to the cobalt matrix of diamond composites causes a decrease in the amount of porosity due to the presence of a liquid phase. The diamond composites which contains tungsten particles in the cobalt bond have a high porosity, and this is due to the high strength and rigidity of tungsten.

2. The composites with tin element in the cobalt matrix exhibit a high hardness, and this is attributed to tin-rich solution hardening. The hardness of the matrix is related to porosity and the addition of an alloying element.

3. The fracture surface of the cobalt bond and nickel-cobalt bond of composites exhibits ductile behaviour, and this is an indication of good bonding among metal powders. A ductile fracture surface with

a concave crack can be formed as a result of silver clustering by the addition of silver to the cobalt bond. The fracture surface for a tungsten–cobalt bond reveals poor bonding among metal powders. The fracture surface of the tin-added cobalt bond shows a less ductile appearance with a tin-rich brittle phase.

4. There is a low value of radial sawblade wear for diamond composites containing higher hardness and lower porosity of bond, and less damage of diamond particles in the circular sawing operation.

Acknowledgements

This research was supported by the Taiwan Diamond Industrial Co. Ltd and General Electric Co. The authors are especially grateful to Dr C. C. Chou, General Manager and Mr C. L. Chen, Manager for their help and advice.

References

1. R. M. GERMAN, "Powder Metallurgy Science" (Metal Powder Industries Federation, Princeton, New Jersey, 1984) p. 209.
2. F. V. LENEL, "Powder Metallurgy Principles and Application" (Metal Powder Industries Federation, Princeton, New Jersey, 1980) p. 492.
3. A. BÜTTNER, *Ind. Dia. Rev.* **34** (1974) 89.
4. D. Kh. BRONSHTEIN, V. G. DELEVI, É. E. SIMKIN and N. V. TSYPIN, *Poroshkovaya Metallurgiya* **9** (1981) 48.
5. R. M. GERMAN, "Liquid Phase Sintering" (Plenum, New York, 1985) p. 187.
6. P. A. BEX and G. R. SHAFTO, *Ind. Dia. Rev.* **44** (1984) 128.
7. R. L. MEHAN and L. E. HIBBS, *ibid.* **24** (1989) 942.
8. Yu. V. NAIDICH, V. P. UMANSKII and I. A. LAVRINENKO, *Ind. Dia. Rev.* **44** (1984) 327.
9. O. A. VORNOV, E. S. CHEBOTAREVA and E. N. YABOLEV, *Sov. J. Superhard Mater.* **9** (1987) 10.

*Received 15 November 1991
and accepted 11 August 1992*